

描述 / Descriptions

SOT23-3 塑封封装 P 道 MOS 场效应管。 P- CHANNEL MOSFET in a SOT23-3 Plastic Package.

特征 / Features

$V_{DS} (V) = -30V$

$I_D = -4.2 A (V_{GS} = -10V)$

$R_{DS(ON)} < 60m\Omega (V_{GS} = -10V)$

$R_{DS(ON)} < 65m\Omega (V_{GS} = -4.5V)$

$R_{DS(ON)} < 120m\Omega (V_{GS} = -2.5V)$

无卤产品。 Halogen free product.

用途 / Applications

适用于作负载开关或脉宽调制应用。

This device is suitable for use as a load switch or in PWM applications.

内部等效电路 / Equivalent Circuit

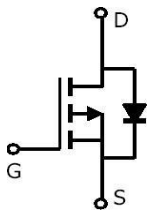

引脚排列 / Pinning

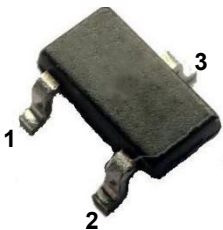

PIN1: G

PIN 2: S

PIN 3: D

印章代码 / Marking

Marking	A19T or 3401
---------	--------------

极限参数 / Absolute Maximum Ratings(Ta=25°C)

参数 Parameter	符号 Symbol	数值 Rating	单位 Unit
Drain-Source Voltage	V_{DS}	-30	V
Drain Current – Continuous	I_D	-4.2	A
Drain Current- Continuous ^A	$I_D(T_a=70^\circ\text{C})$	-3.5	A
Pulsed Drain Current ^B	I_{DM}	-30	A
Gate-Source Voltage	V_{GS}	± 12	V
Total Power Dissipation ^A	P_D	1.4	W
Total Power Dissipation ^A	$P_D(T_a=70^\circ\text{C})$	1.0	W
Operating and Storage Junction Temperature Range	T_J, T_{STG}	-55 to 150	$^\circ\text{C}$
Maximum Junction-to-Ambient ^A	$R_{\theta JA}$	125	$^\circ\text{C/W}$
Maximum Junction-to-Lead ^C	$R_{\theta JL}$	60	$^\circ\text{C/W}$

电性能参数 / Electrical Characteristics(Ta=25°C)

参数 Parameter	符号 Symbol	测试条件 Test Conditions	最小值 Min	典型值 Typ	最大值 Max	单位 Unit
Drain–Source Breakdown Voltage	BV_{DSS}	$V_{GS}=0V$ $I_D=-250\mu A$	-30			V
Zero Gate Voltage Drain Current	I_{DSS}	$V_{DS}=-24V$ $V_{GS}=0V$			-1	μA
		$V_{DS}=-24V$ $V_{GS}=0V$ $T_J=55^\circ\text{C}$			-5	μA
Gate–Body Leakage.	I_{GSS}	$V_{GS}=\pm 12V$ $V_{DS}=0V$			± 0.1	μA
On–State Drain Current	$I_{D(on)}$	$V_{GS}=-4.5V$ $V_{DS}=-5V$	-25			A
Gate Threshold Voltage	$V_{GS(th)}$	$V_{DS}=V_{GS}$ $I_D=-250\mu A$	-0.7	-1	-1.3	V
Static Drain–Source On–Resistance	$R_{DS(on)(1)}$	$V_{GS}=-10V$ $I_D=-4.2A$		52	60	m Ω
	$R_{DS(on)(2)}$	$V_{GS}=-10V$ $I_D=-4.2A$ $T_J=125^\circ\text{C}$			75	
	$R_{DS(on)(3)}$	$V_{GS}=-4.5V$ $I_D=-4A$		60	65	
	$R_{DS(on)(4)}$	$V_{GS}=-2.5V$ $I_D=-1A$		75	120	
Forward Transconductance	g_{FS}	$V_{DS}=-5V$ $I_D=-5A$	4	8		S
Drain–Source Diode Forward Voltage	V_{SD}	$V_{GS}=0V$ $I_S=-1A$		-0.75	-1.0	V

电性能参数 / Electrical Characteristics(Ta=25°C)

参数 Parameter	符号 Symbol	测试条件 Test Conditions	最小值 Min	典型值 Typ	最大值 Max	单位 Unit
Input Capacitance	C_{iss}	$V_{DS}=-15V$ $V_{GS}=0V$ $f=1MHz$		957		pF
Output Capacitance	C_{oss}			115		
Reverse Transfer Capacitance	C_{rss}			77		
Gate resistance	R_g	$V_{GS}=0V$ $V_{DS}=0V,$ $f=1MHz$		6		Ω
Total Gate Charge	Q_g	$V_{GS}=-4.5V$ $V_{DS}=-15V$ $I_D=-4A$		9.4		nC
Gate Source Charge	Q_{gs}			2		
Gate Drain Charge	Q_{gd}			3		
Turn-On Delay Time	$t_{d(on)}$	$V_{GS}=-10V$ $R_L=3.6\Omega$ $V_{DS}=-15V$ $R_{GEN}=6\Omega$		6.3		ns
Turn-On Rise Time	t_r			3.2		
Turn-Off Delay Time	$t_{d(off)}$			38.2		
Turn-Off Fall Time	t_f			12		
Body Diode Reverse Recovery Time	t_{rr}	$I_F=-4A, di/dt=100A/\mu s$		20.2		ns
Body Diode Reverse Recovery Charge	Q_{rr}	$I_F=-4A, di/dt=100A/\mu s$		11.2		nC

A: The value of $R_{\theta JA}$ is measured with the device mounted on 1in² FR-4 board with 2oz. Copper, in a still air environment with $T_A=25^\circ C$. The value in any given application depends on the user's specific board design. The current rating is based on the $t \leq 10s$ thermal resistance rating.

B: Repetitive rating, pulse width limited by junction temperature.

C. The $R_{\theta JA}$ is the sum of the thermal impedance from junction to lead $R_{\theta JL}$ and lead to ambient.

D. The static characteristics in Figures 1 to 6,12,14 are obtained using 80 μs pulses, duty cycle 0.5% max.

E. These tests are performed with the device mounted on 1 in² FR-4 board with 2oz. Copper, in a still air environment with $T_A=25^\circ C$. The SOA curve provides a single pulse rating.

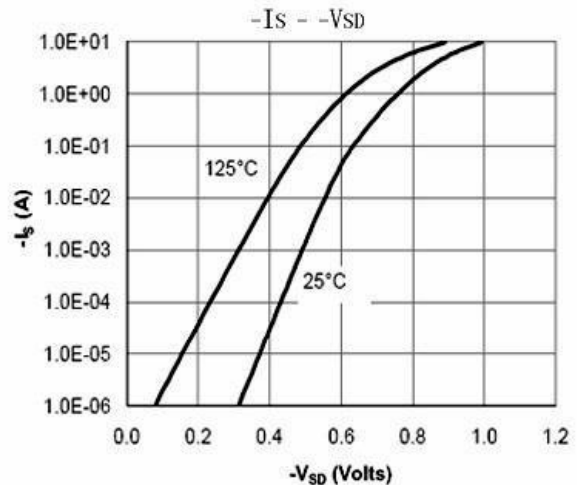
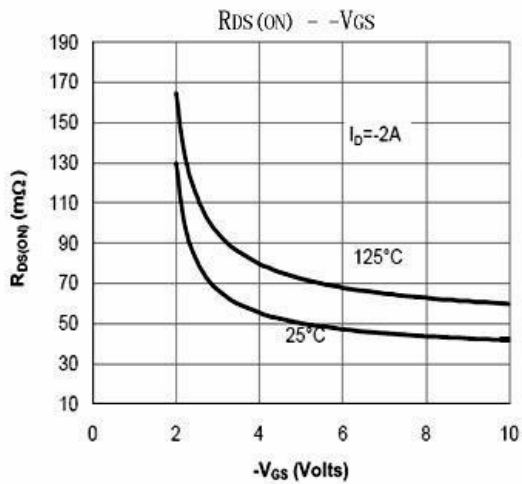
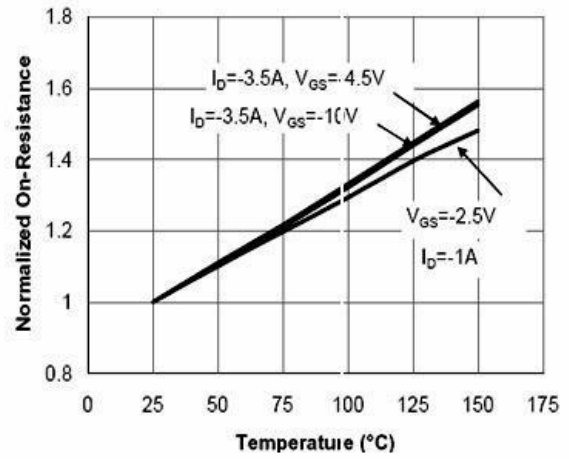
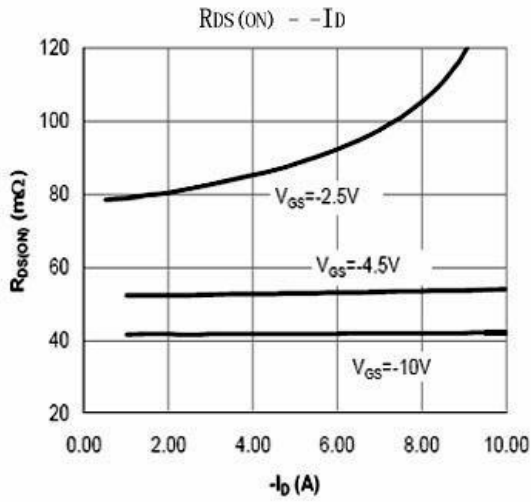
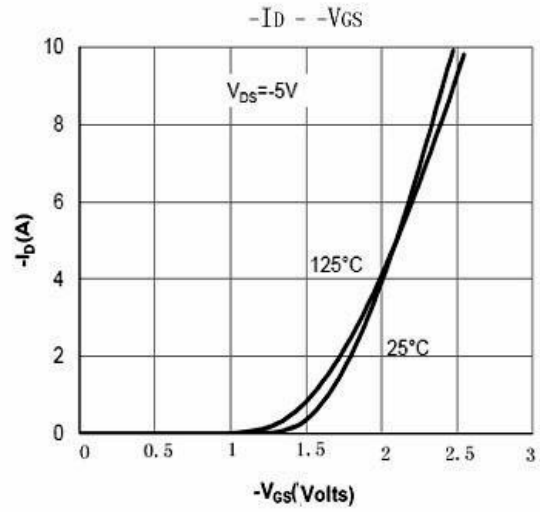
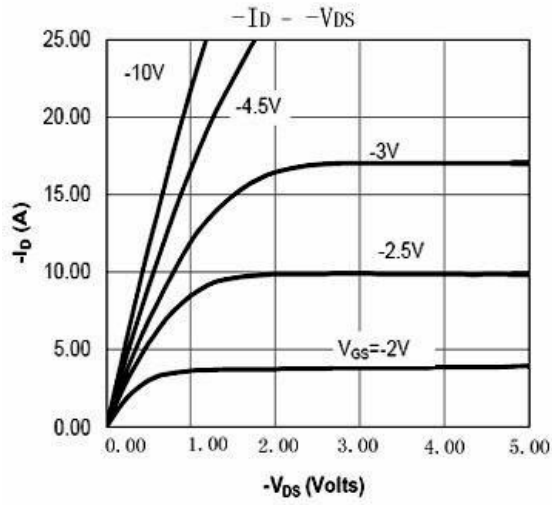

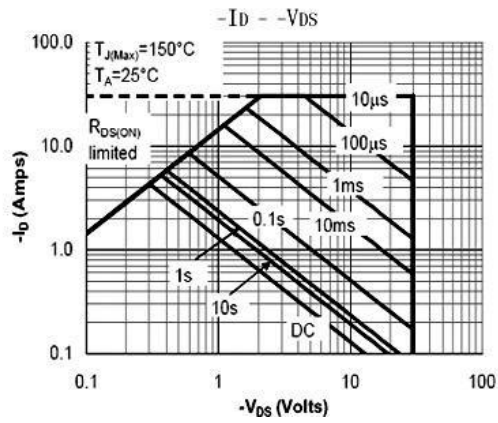
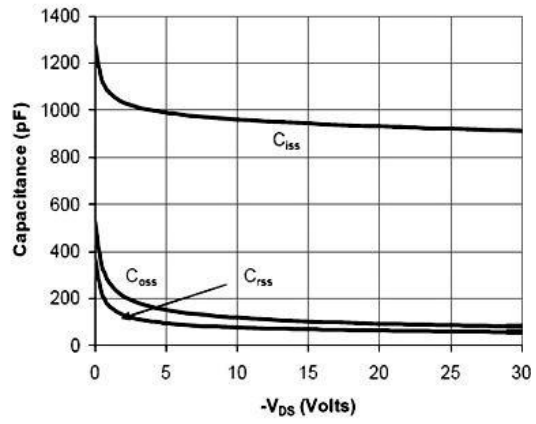
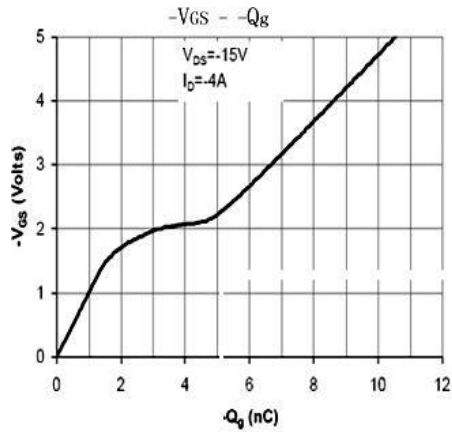

外形尺寸图 / Package Dimensions

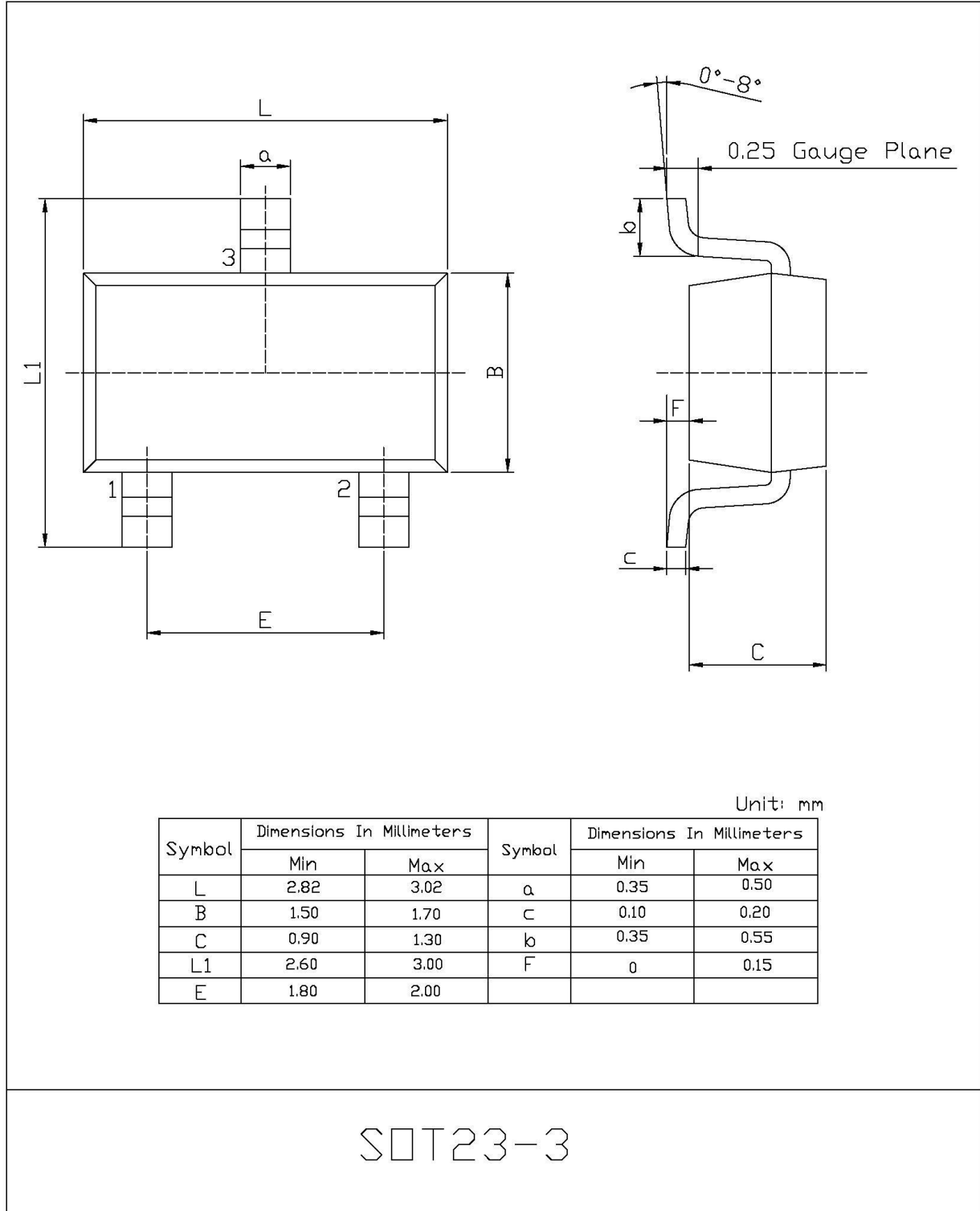

印章说明 / Marking Instructions

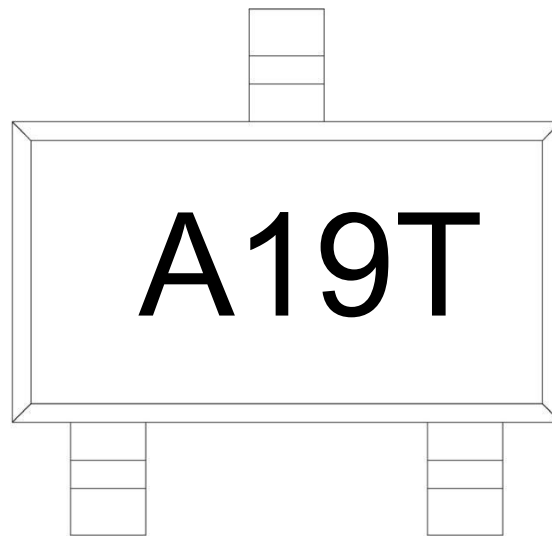

说明:

A19或3400: 为型号代码

T: 为公司代码

Note:

A19 or 3400: Product Type Code.

T: Company Code.

回流焊温度曲线图(无铅) / Temperature Profile for IR Reflow Soldering(Pb-Free)

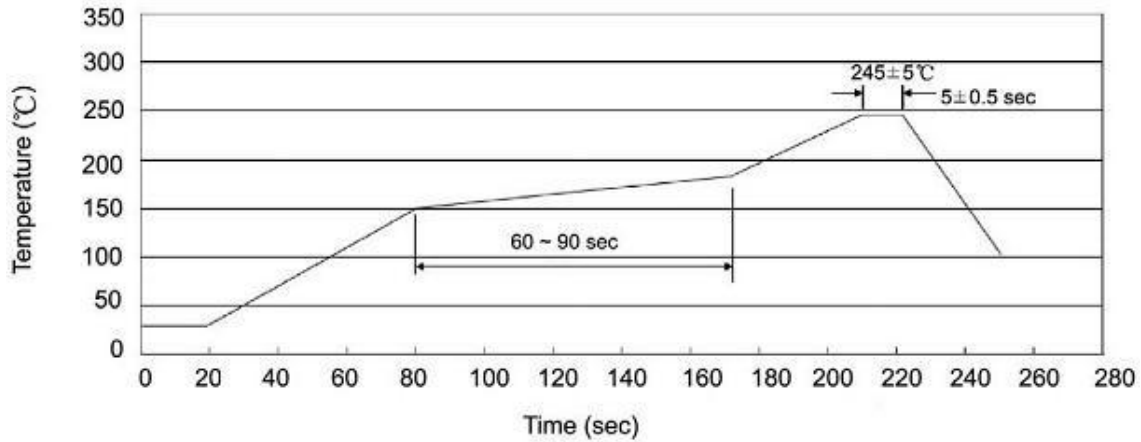

说明:

- 1、预热温度 150 ~ 180°C, 时间 60 ~ 90sec;
- 2、峰值温度 245±5°C, 时间持续为 5±0.5sec;
- 3、焊接制程冷却速度为 2 ~ 10°C/sec.

Note:

- 1.Preheating:150~180°C, Time:60~90sec.
- 2.Peak Temp.:245±5°C, Duration:5±0.5sec.
3. Cooling Speed: 2~10°C/sec.

耐焊接热试验条件 / Resistance to Soldering Heat Test Conditions

温度: 260±5°C

时间: 10±1 sec.

Temp.:260±5°C

Time:10±1 sec

包装规格 / Packaging SPEC.

卷盘包装 / REEL

Package Type 封装形式	Units 包装数量					Dimension 包装尺寸 (unit: mm ³)		
	Units/Reel 只/卷盘	Reels/Inner Box 卷盘/盒	Units/Inner Box 只/盒	Inner Boxes/Outer Box 盒/箱	Units/Outer Box 只/箱	Reel	Inner Box 盒	Outer Box 箱
SOT-23-3	3,000	10	30,000	4	120,000	7" x8	210×205×205	445×230×435

使用说明 / Notices